



CADE Accumulator Technology Brochure



ENGINEERING YOUR SUCCESS.

CADE –

Cylinder and Accumulator Division Europe

Made in Europe - serving all markets and industries

Parker CADE UK
Sandycroft, (Chester)

Parker CADE Sweden
Falköping

Parker CADE France
Colombes

Parker CADE Poland
Wroclaw

Parker CADE Italy
Arsago

Parker CADE Germany
Cologne

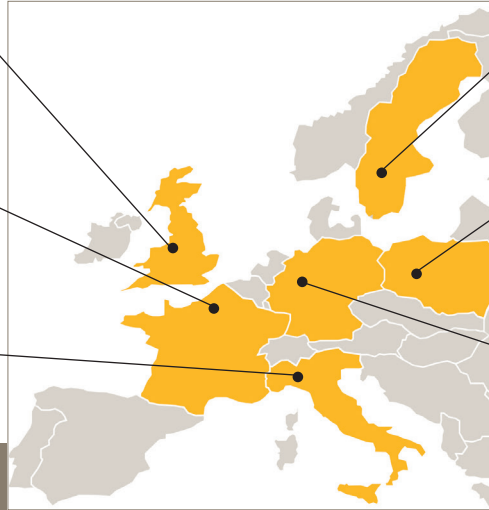

www.parker/acde



Our product range - click for more detail:



Bladder Accumulators



Piston Accumulators



Membrane Accumulators



Pulsation Dampers

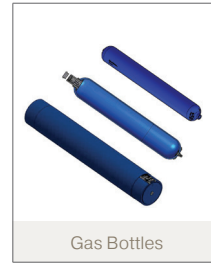

Gas Bottles



Accessories

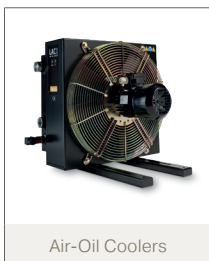

Air-Oil Coolers

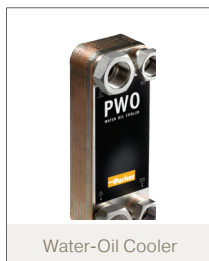

Water-Oil Cooler



QPM Pump



Tierod Cylinders



Mill-type Cylinders



HELAC®
Helical Actuators

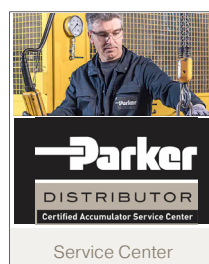

Service Center

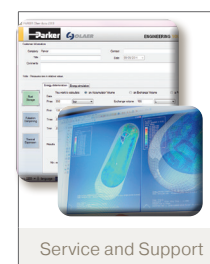

Service and Support



Cross Reference Tool

Contents

	Page
Selecting and Applying Accumulators	4
Design Features and Construction	5
Operation	6
Accumulator Selection	7
Gas Bottle Installation	10
Large / Multiple Accumulators	11
Precharging	12
Failure Prevention	15
Solutions for Oil & Gas and Power Generation	16
Solutions for Mobile Applications	18
Accumulator Operating Principle	21
Regulations and Approvals	22
Multi-national Certifications	22
Accumulator Range on parker.com	23

If you are using an electronic version of this catalogue
this icon will take you back to this **CONTENTS** page upon clicking.



Selecting and Applying Accumulators

In industrial and mobile applications, three types of hydro-pneumatic accumulators – piston, bladder and diaphragm – are used. Each has particular advantages and limitations which should be considered when selecting an accumulator for a specific application.

Bladder/Diaphragm accumulators are generally preferred for applications where rapid cycling, high fluid contamination and fast response times are required. They provide excellent gas/fluid separation.

Piston accumulators offer greater efficiency and flexibility in most applications, due to their wider range of sizes. Parker's piston accumulators feature a five-blade V-O-ring which maintains full contact between the piston and the bore, without rolling. Sealing remains effective even under rapid cycling at high operating pressures. Bladder accumulators

MAKING THE RIGHT CHOICE - SUMMARY TABLE

	PISTON	BLADDER	DIAPHRAGM
PRECHARGE SENSING	Yes	No	No
Flow Rate	Highest	Avg / Med	Low
Temperature Tolerance Range	Highest	High	Avg / Med
OUTPUT / COMPRESSION RATIOS	HIGH	≤ 4:1	4:1 to 8:1
Servicability	High	High	Non-Repairable
Dirt Tolerance	Low	High	High
Response Time	See Fig. 4 & 5	Quick	Quick
Water Tolerance	Avg / Med	High	-
Low Lubricity Fluid Tolerance	Avg / Med	High	High
Weight	Size Dependent	Size Dependent	Lightest
OPERATING PRESSURES	UP TO XX BAR	UP TO XX BAR	UP TO XX BAR
Failure Mode	Progressive	Sudden	Sudden
Size / Envelope	Custom Length / Diameters	One Choice per Capacity	One Choice per Capacity

* With ASME Appendix 22

Design Features and Construction

Parker's bladder accumulators

feature a non-pleated, flexible rubber bladder housed within a steel shell. A steel gas valve is molded on the top of the bladder. A poppet valve, normally held open by spring force, prevents the bladder from extruding through the port when the bladder is fully expanded in the shell. Parker's bladder accumulators are available as either top or bottom repairable units, for optimum flexibility.

Diaphragm accumulators

Parker's diaphragm accumulators feature a one-piece molded diaphragm which is mechanically sealed to the high strength metal shell. The flexible diaphragm provides excellent gas and fluid separation. The non-repairable electron-beam welded construction reduces size, weight, and ultimately cost.

The bladder/diaphragm is charged with a dry inert gas, such as high purity nitrogen, to a set precharge pressure determined by the system requirements. As system pressure fluctuates, the bladder/diaphragm expands and contracts to discharge fluid from, or allow fluid into, the accumulator shell.

Piston accumulators

Parker's piston accumulators consist of a cylindrical body, sealed by a gas cap and charging valve at the gas end, and by a hydraulic cap at the opposite end. A lightweight piston separates the gas side of the accumulator from the hydraulic side.

As with the bladder/diaphragm accumulator, the gas side is charged with high purity nitrogen to a predetermined pressure. Changes in system pressure cause the piston to glide up and down along the shell, allowing fluid to enter or forcing it to be discharged from the accumulator body.

Fig. 1 Typical bladder, diaphragm and piston accumulator cross section

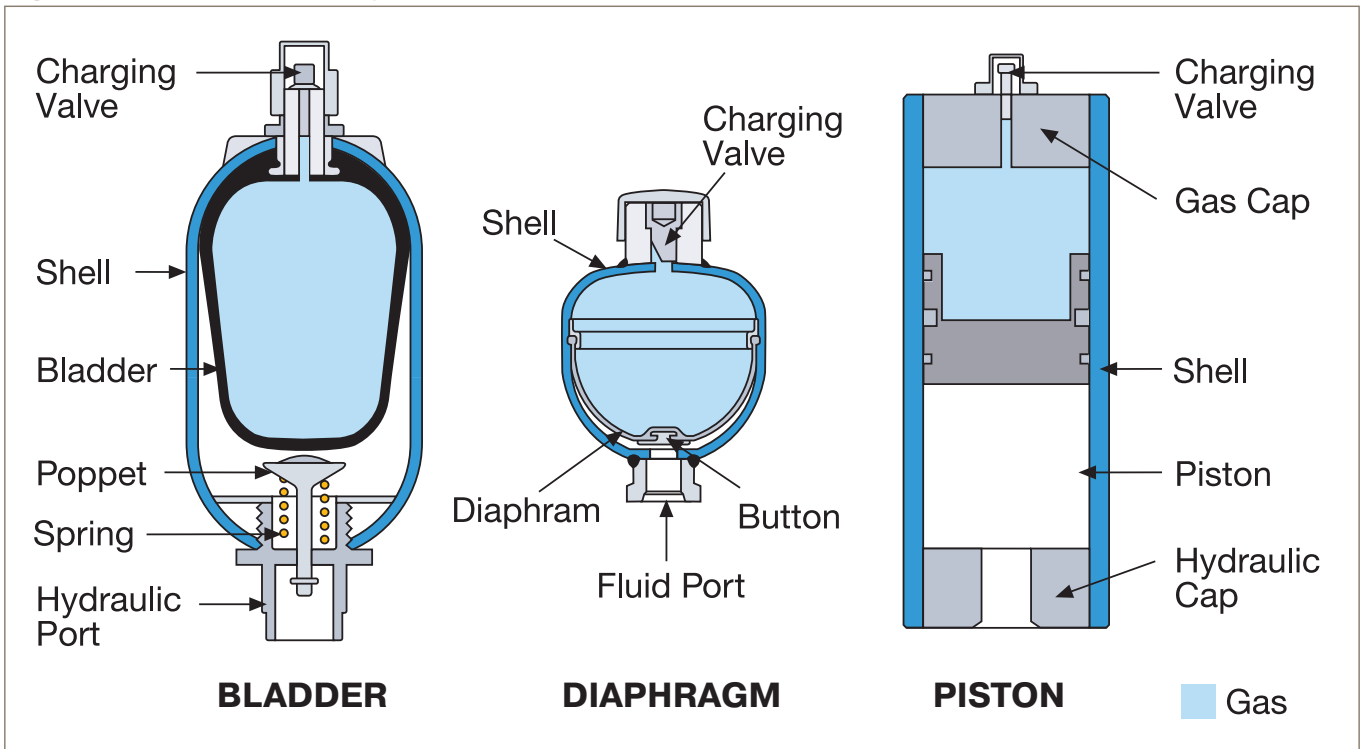

Operation

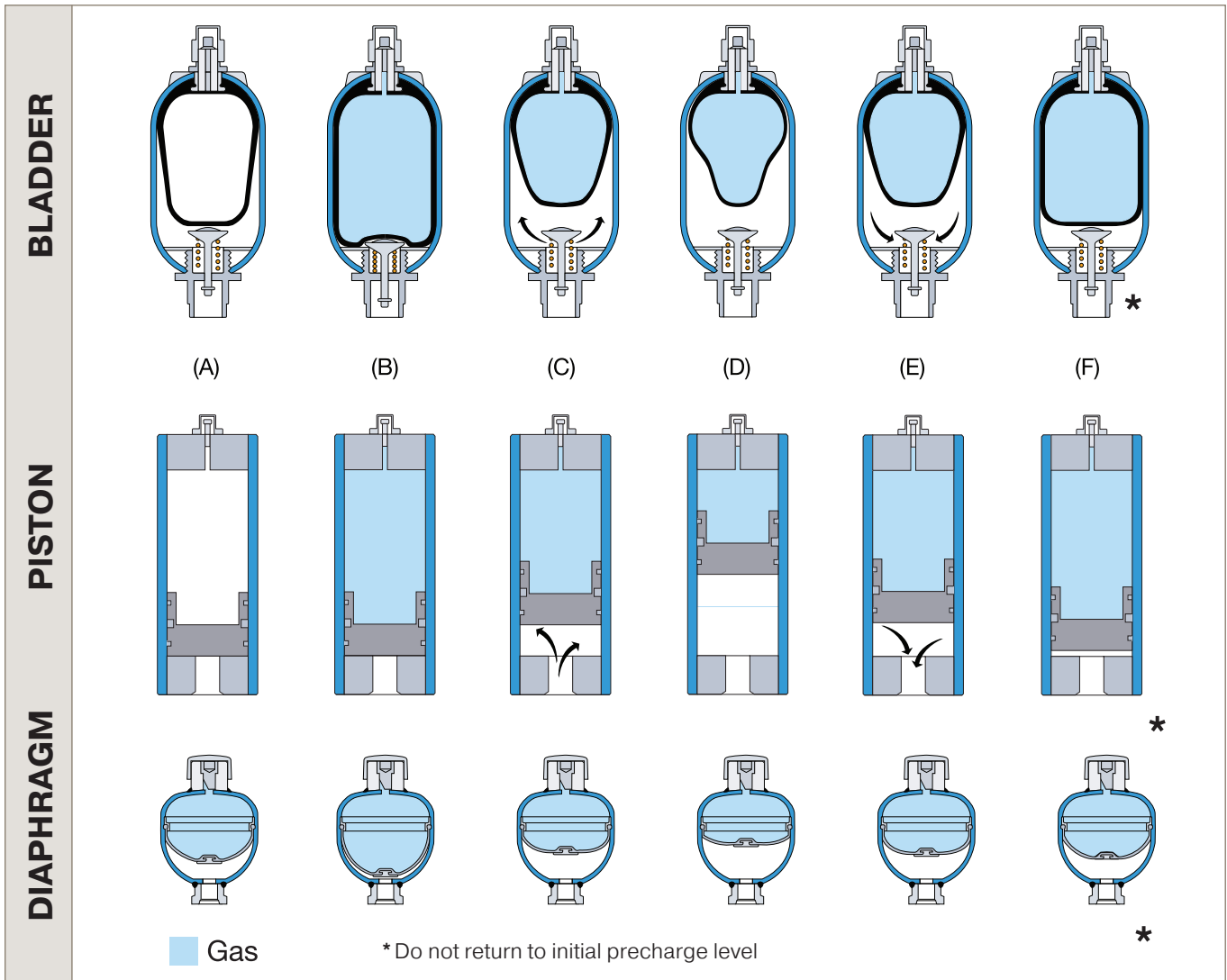

Fig. 2 Operating conditions of bladder, piston, and diaphragm style accumulators

Stage A
The accumulator is empty, and neither gas nor hydraulic sides are pressurized.

Stage B
The accumulator is precharged.

Stage C
The hydraulic system is pressurized. As system pressure exceeds gas precharge hydraulic pressure fluid flows into the accumulator.

Stage D
System pressure peaks. The accumulator is filled with fluid to its design capacity. Any further increase in hydraulic pressure is prevented by a relief valve in the hydraulic system.

Stage E
System pressure falls. Precharge pressure forces fluid from the accumulator into the system.

Stage F
Minimum system pressure is reached. The accumulator has discharged its design maximum volume of fluid back into the system.

Accumulator Selection

When selecting an accumulator for a particular application, both hydraulic system and accumulator performance criteria should be considered. To ensure long and satisfactory service life, the following factors should be taken into account:

- failure mode
- output volume
- flow rate
- fluid type
- response time
- shock suppression
- high-frequency cycling
- mounting position
- external forces
- sizing information
- certification
- safety
- temperature effect
- dwell time

Failure modes

In certain applications, a sudden failure may be preferable to a gradual failure. A high-speed machine, for example, where product quality is a function of hydraulic system pressure. Because sudden failure is detected immediately, scrap is minimized, whereas gradual failure might mean that production of a large quantity of sub-standard product could occur before the failure became apparent. A bladder/diaphragm accumulator would be most suitable for this application.

Conversely, where continuous operation is paramount and sudden failure could be detrimental, for example, in a braking or steering circuit on mobile equipment, a progressive failure mode is desirable. In this application, a piston accumulator would be appropriate.

Output volume

The maximum available capacity of each type of accumulator determines the limits of their suitability where large output volumes are required. There are, however, several methods of achieving higher output volumes than standard accumulator capacities suggest (see Large/Multiple Accumulators, page 11).

Table 1: Relative Outputs of a 10 Gallon Accumulator

Compression Ratio	System Pressure PSI		Recommended Precharge PSI		Fluid Output Gallons	
	max	min	Bladder	Piston	Bladder	Piston
1.5	3000	2000	1800	1900	2.79	3.00
2	3000	1500	1350	1400	4.23	4.41
3	3000	1000	900	900	5.70	5.70
6	3000	500	*	400	*	6.33

*Below recommended minimum operating ratio of 4:1

Table 1 compares typical fluid outputs for Parker's 10-gallon piston and bladder accumulators operating isothermally as auxiliary power sources over a range of minimum system pressures. The higher precharge pressures recommended for piston accumulators result in higher outputs than from comparable bladder accumulators. Also, bladder accumulators are not generally suitable for compression ratios greater than 4:1, as these could result in excessive bladder deformation, higher gas temperature, excessive side wall wear, and eventual failure.

Piston accumulators have an inherently higher output relative to their overall dimensions, which may be critical in locations where space is limited. Piston accumulators are available in a choice of diameters and lengths for a given capacity, whereas bladder and diaphragm accumulators are frequently offered in only one size per capacity, and fewer sizes are available. Piston accumulators can also be built to custom lengths for applications in which available space is critical.

Flow rate

Table 2 shows typical maximum flow rates for Parker's accumulator styles in a range of sizes.

The larger standard bladder accumulator designs are limited to 220 GPM, although this may be increased to 600 GPM using a larger high-flow port. Flow rates greater than 600 GPM may be achieved by mounting several accumulators on a common manifold. (see Large/Multiple Accumulators, page 11).

Table 2: Maximum Recommended Accumulator Flow Rates

GPM at 3000 PSI						
Piston Bore	Bladder Capacity	Diaphragm Capacity	Piston	Bladder Std.	Bladder High-flow	Diaphragm
2	1 qt.	.5-10 cu. in.	100	40		11
3	1 gal.	20-85 cu. in.	220	150		26
4	2.5 gal.	120-170 cu. in.	400	220	600	42
6	and		800	220	600	
7	Larger		1200	220	600	
9			2000	220	600	
12			3400			

For a given system pressure, flow rates for piston accumulators generally exceed those for bladder designs. Flow is limited by piston velocity, which should not exceed 10 ft/sec. to avoid piston seal damage. In high-speed applications, high seal contact temperatures and rapid decompression of nitrogen that has permeated the seal itself, can cause blisters, cracks and pits on the seal surface.

Contamination / Fluid type
Bladder/diaphragm accumulators are more resistant to damage caused by contamination of the hydraulic fluid than piston types. While some risk exists from contaminants trapped between the bladder and the shell, a higher risk of failure exists from the same contaminants acting on the piston seal.

Bladder accumulators are usually preferred to piston type accumulators for water service applications. Water systems tend to carry more solid contaminants and lubrication is poor. Both the piston and bladder type units require some type of preparation to resist corrosion on the wetted surfaces.

Piston accumulators are preferred for systems using exotic fluids or where extremes of temperature are experienced as compared to bladders. Piston seals are

more easily molded in the required special compounds, and may be less expensive.

Response time
In theory, bladder/diaphragm accumulators should respond more quickly to system pressure variations than piston accumulator types, since there is no static friction to overcome with a piston seal, and there is no piston mass to be accelerated or decelerated. This is particularly true in small capacity, lower pressure applications. In practice, however, the difference in response is not great, and is probably insignificant in most applications.

This applies equally in servo applications, as only a small percentage of servos require response times of 25 ms or less. This is the point where the difference in response between piston and bladder accumulators becomes significant. Generally, a bladder accumulator should be used for applications requiring less than 25 ms response time, and either accumulator type for a response of 25 ms or greater.

Shock suppression
Shock control does not necessarily demand a bladder/diaphragm accumulator.

Example 1

A test circuit (Fig. 3) includes a control valve situated 118 feet from a pump supplying fluid at 29.6 GPM. The circuit uses 1.25-inch tubing, and the relief valve is set to open at 2750 PSI. Shutting the control valve (Fig. 4) produces a pressure spike of 385 PSI over relief valve setting (blue trace).

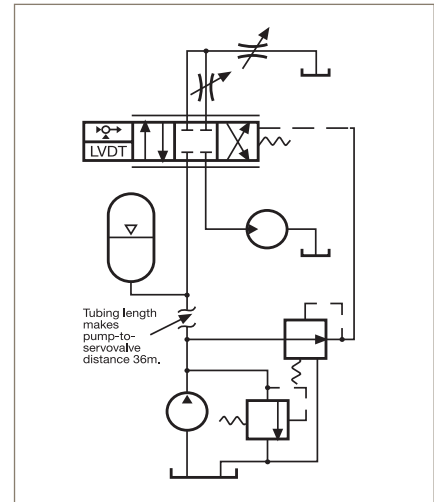

Fig. 3 Test circuit to generate and measure shock waves in a hydraulic system

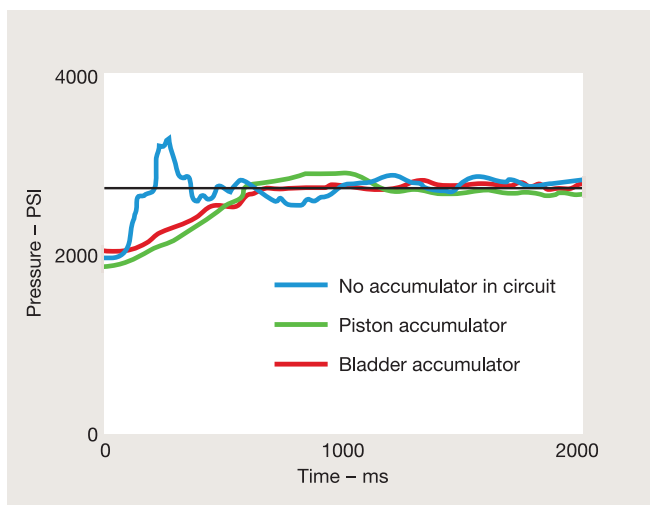

Fig. 4 Shock wave test results – Example 1

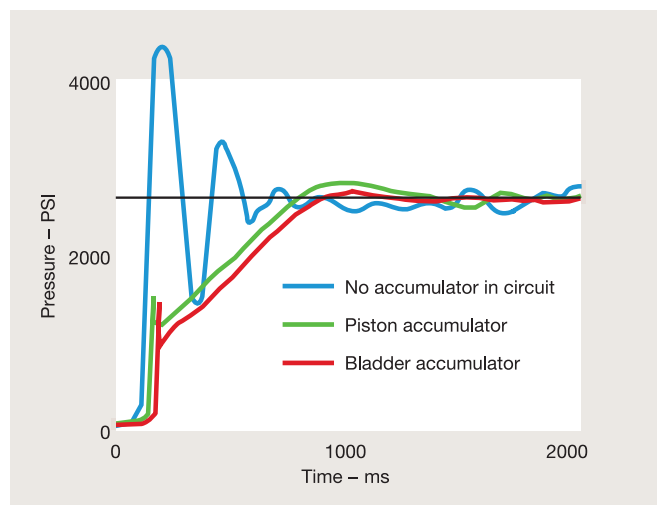

Fig. 5 Shock wave test results – Example 2

Installing a Parker one-gallon piston accumulator at the valve reduces the transient to 100 PSI over relief valve setting (green trace). Substituting a one-gallon bladder accumulator further reduces the transient to 80 PSI over relief valve setting (red trace), an improvement of only 20 PSI and of little practical significance.

Example 2

A second, similar test using 0.625-inch tubing and a relief valve setting of 2650 PSI (Fig. 5) results in a pressure spike of 2011 PSI over relief valve setting without an accumulator (blue trace). A Parker piston accumulator reduces the transient to 107 PSI over relief valve setting (green trace), while a bladder accumulator achieves a transient of 87 PSI over relief valve setting (red trace). The difference between accumulator types in shock suppression is again negligible.

High-frequency cycling

High-frequency system pressure cycling can cause a piston accumulator to 'dither', with the piston cycling rapidly back and forth in a distance less than its seal width. Over an extended period, this condition may cause heat buildup under the seal due to lack of lubrication, resulting in seal and bore wear. For high frequency dampening applications, therefore, a bladder/diaphragm accumulator was generally used. However, Parker has recently developed special piston seals that perform as effective as bladder/diaphragm accumulators.

Mounting position

The optimum mounting position for any accumulator is vertical, with the hydraulic port downwards. Piston accumulators can be mounted horizontally if the fluid is kept clean but, if solid contaminants are present or expected in significant amounts, horizontal mounting can result in uneven or accelerated seal wear. A bladder accumulator may also be

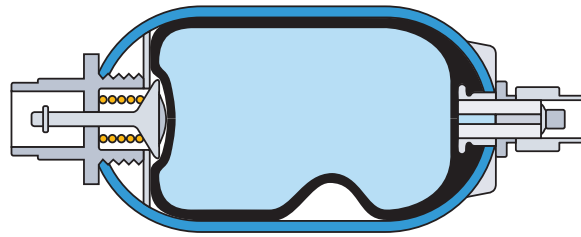

Fig. 6 A horizontally mounted bladder accumulator can trap fluid away from the hydraulic valve

mounted horizontally, but uneven wear on the side of the bladder as it rubs against the shell while floating on the fluid can reduce its service life and even cause permanent distortion. The extent of the damage will depend upon fluid cleanliness, cycle rate and compression ratio (i.e., maximum system pressure divided by minimum system pressure). In extreme cases, fluid can be trapped away from the hydraulic port (Fig. 6), reducing output, as the bladder extends, forcing the poppet valve to close prematurely. Horizontal mount in high-flow applications is not recommended as the bladder can be pinched by the poppet.

External forces

Any application subjecting an accumulator to acceleration, deceleration or centrifugal force may have a detrimental effect on its operation, and could cause damage to a bladder accumulator. Forces along the axis of the tube or shell normally have little effect on a bladder accumulator but may cause a variation in gas pressure in a piston accumulator due to the mass of the piston.

Forces perpendicular to an accumulator's axis should not affect a piston accumulator, but fluid in a bladder accumulator may be thrown to one side of the shell (Fig. 7), displacing the bladder and flattening and lengthening it. In this condition, fluid discharge could cause the poppet valve

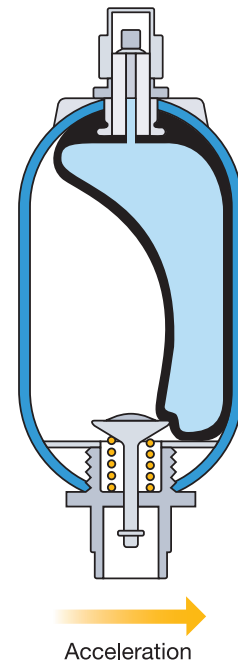

Fig. 7 Perpendicular force causes the mass of the fluid to displace the bladder

to pinch and cut the bladder. Higher precharge pressures increase the resistance of the bladder to the effects of perpendicular forces.

Sizing information

Accurate sizing of an accumulator is critical if it is to deliver a long and reliable service life. Information

and worked examples are shown in Parker's accumulator catalogues, or accumulator size can be calculated automatically by entering application details into Parker's accumulator inPHorm software selection program. Please contact your local Parker distributor for details, or contact us at www.parker.com/accumulator.

Safety

Hydro-pneumatic accumulators should always be used in conjunction with a safety block, to enable the accumulator to be isolated from the circuit in an emergency or for maintenance purposes.

Remote gas storage offers installation flexibility where the available space or position cannot accommodate an accumulator of the required size. A

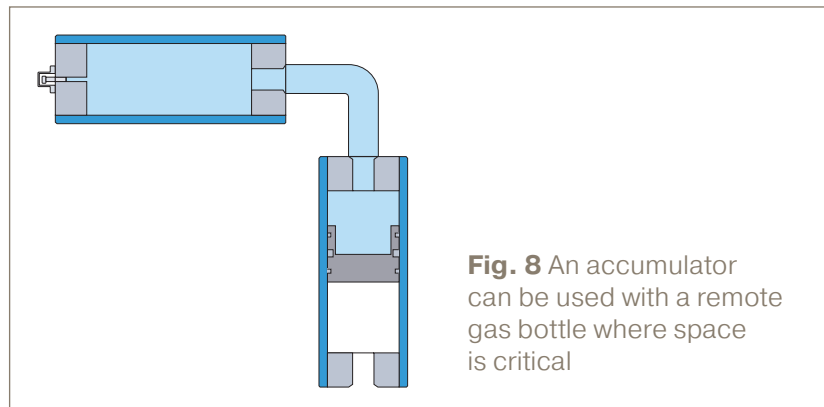

Fig. 8 An accumulator can be used with a remote gas bottle where space is critical

Gas Bottle Installations

smaller accumulator may be used in conjunction with a Parker auxiliary gas bottle, which can be located elsewhere (**Fig. 8**).

The gas bottle is sized by the formula:

For Piston:

gas bottle size = accumulator size - (required output from accumulator x 1.1)

For Bladder Type Accumulators:

gas bottle size = accumulator size - (required output from accumulator x 1.25)

For example, an application that calls for a 30-gallon accumulator may only actually require eight gallons of fluid output. This application could therefore be satisfied with a 10-gallon accumulator and a 20-gallon gas bottle.

Gas bottle installations may use either bladder or piston accumulators, subject to the following considerations:

- **Any accumulator used with remote gas storage should generally have the same size port at the gas end as at the hydraulic end, to allow an unimpeded flow of gas to and from the gas bottle. The gas bottle will have an equivalent port in one end and a gas charging valve at the other.**
- **A piston accumulator should be carefully sized to prevent the piston bottoming at the end of the cycle. Bladder accumulators should be sized to prevent filling to more than 75% full.**
- **Bladder accumulators require a special device called a transfer barrier tube at the gas end, to prevent extrusion of the bladder into the gas bottle piping. The flow rate between the bladder transfer barrier tube and its gas bottle will be restricted by the neck of the transfer barrier tube.**
- **Because of the above limitations, piston accumulators are generally preferred to bladder types for use in gas bottle installations.**
- **Diaphragm accumulators are normally not used in conjunction with gas bottles.**



The bladder/transfer barrier should never be filled more than 75% full

Large/Multiple Accumulators

The requirement for an accumulator with an output of more than 50 gallons cannot usually be met by a single accumulator, because larger piston designs are relatively

expensive, and bladder designs are not generally available in these sizes. The requirement, however, can be met using one of the multiple-component installations shown in **Figs. 9 and 10**.

is that a single seal failure could drain the whole gas system. Note: The addition of individual isolation valves on the gas bottles remedies this issue.

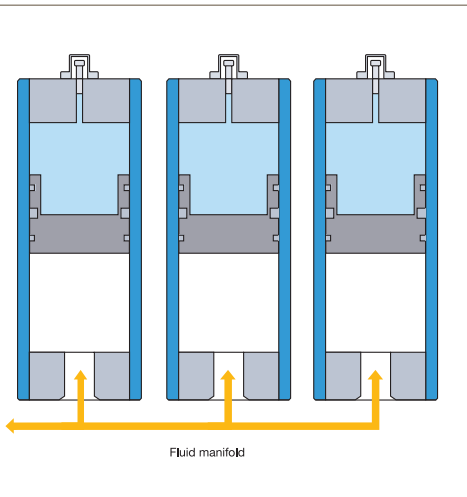

Fig. 9 Multiple accumulators manifolded together offer high system flow rates

The installation in **Fig. 10** consists of several gas bottles serving a single piston accumulator through a gas manifold. The accumulator portion may be sized outside of the limitations of the sizing formula on page 14, but should not allow the piston to strike the caps repeatedly while cycling. The larger gas volume available with this configuration allows a relatively greater piston movement – and hence fluid output – than with a conventionally sized single accumulator. A further advantage is that, because of the large precharge ‘reservoir’, gas pressure is relatively constant over the full discharge cycle of the accumulator. The major disadvantage of this arrangement

The installation in **Fig. 9** uses several accumulators, of piston or bladder design, mounted on a hydraulic manifold. Two advantages of multiple accumulators over multiple gas bottles are that higher unit fluid flow rates are permissible, and a single leak will not drain precharge pressure from the entire system.

A potential disadvantage is that, where piston accumulators are used, the piston with the least friction will move first and could occasionally bottom on the hydraulic end cap. However, in a slow or infrequently used system, this would be of little significance.

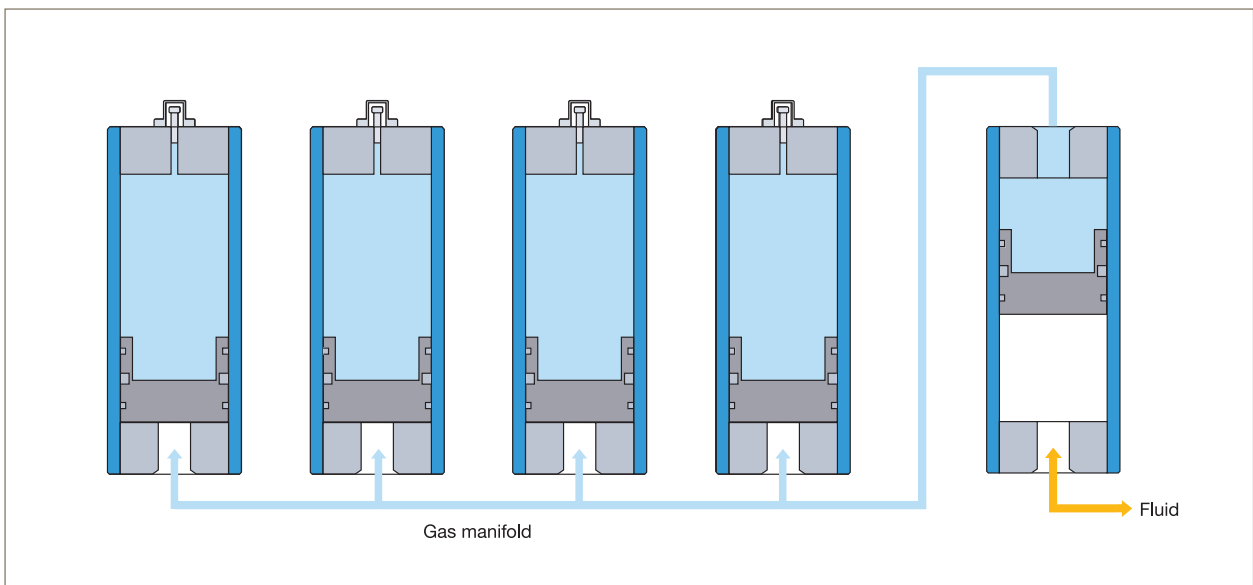

Fig. 10 Several gas bottles can supply precharge pressure to a single accumulator

Precharging

Precharging process

Correct precharging involves accurately filling the gas side of an accumulator with a high purity dry, inert gas, before admitting fluid to the hydraulic side.

It is important to precharge an accumulator to the correct specified pressure. Precharge pressure determines the volume of fluid retained in the accumulator at minimum system pressure. In an energy storage application, a bladder/diaphragm accumulator is typically precharged to 90% of minimum system pressure, and a piston accumulator to 95% of minimum system pressure at the system operating temperature.

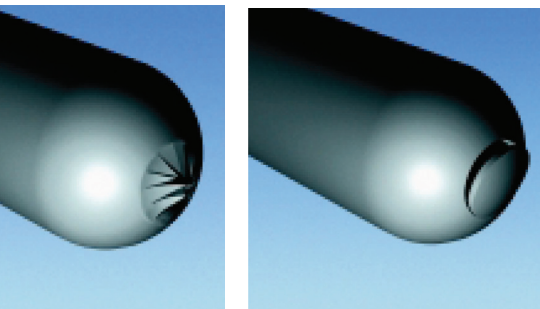

Fig. 11 (Left) Starburst rupture caused by loss of bladder elasticity

Fig. 12 (Right) C-shaped cut shows that bladder has been trapped under poppet

The ability to correctly carry out and maintain precharging is an important factor when choosing the type of accumulator for an application.

Bladder accumulators are far more susceptible to damage during precharging than piston types. Before precharging and entering in service, the inside of the shell should

be thoroughly lubricated with system fluid.

This fluid acts as a cushion, and lubricates and protects the bladder as it expands. When precharging, the first 50 PSI of nitrogen should be introduced slowly. Failure to follow this precaution could result in immediate bladder failure: high-pressure nitrogen, expanding rapidly and thus cold, could form a channel in the folded bladder, concentrating at the bottom. Once the poppet valve has closed, the precharge can be increased to the desired pressure.

The chilled, brittle rubber, expanding rapidly would then inevitably rupture (**Fig. 11**). The bladder could also be forced under the poppet, resulting in a cut (**Fig. 12**).

Close attention should be paid to operating temperature during precharging, as a rise in temperature will cause a corresponding increase in pressure which could then exceed the precharge limit.

Little damage can occur when precharging or checking the precharge on a piston accumulator, but care should be taken to make sure the accumulator is void of all fluid to prevent getting an incorrect reading on the precharge. The protective cover on the hydraulic port must be removed prior to precharging. This will prevent the cover from flying off if the piston is not resting on the hydraulic cap.

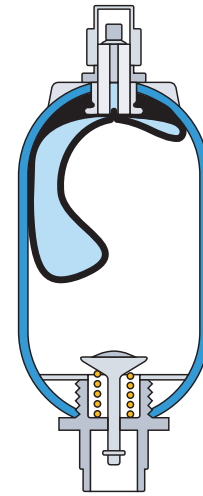

Fig. 13 Fluid entering an unprecharged bladder accumulator has forced the bladder into the gas stem

Excessively high precharge

Excessive precharge pressure or a reduction in the minimum system pressure without a corresponding reduction in precharge pressure may cause operating problems or damage to accumulators.

With excessive precharge pressure, a piston accumulator will cycle between stages (e) and (b) of

Fig. 2, and the piston will travel too close to the hydraulic end cap. The piston could bottom at minimum system pressure, reducing output and eventually damaging the piston and piston seal. The piston can often be heard bottoming, warning of impending problems.

An excessive precharge in a bladder accumulator can drive the bladder into the poppet assembly when cycling between stages (e) and (b). This could cause fatigue failure of the poppet spring assembly, or even a pinched and cut bladder, should it become trapped beneath the poppet as it is forced closed (**Fig. 12**).

Excessive precharge pressure is the most common cause of bladder failure.

Excessively low precharge

Excessively low precharge pressure or an increase in system pressure without a corresponding increase in precharge pressure can also cause operating problems and subsequent accumulator damage. With no precharge in a piston accumulator, the piston will be driven into the gas end cap and will often remain there. Usually, a single contact will not cause any damage, but repeated impacts will eventually damage the piston and seal.

Conversely, for a bladder accumulator, too low or no precharge can have rapid and severe consequences. The bladder will be crushed into the top of the shell and can extrude into the gas stem and be punctured (**Fig. 13**). This condition is known as “pick out.” One such cycle is sufficient to destroy a bladder. Overall, piston accumulators are generally more tolerant of careless precharging. Note: A pick out appears as a pin hole at the base of the bladder stem.

Monitoring piston accumulator precharge

Several methods can be used to monitor the precharge pressure of Parker’s piston accumulators. Note that, in **Fig. 14b**, the flat piston must be used to enable the sensor to register its position.

- **With the hydraulic system shut down, cool and accumulator emptied of fluid: A pressure transducer or gauge located in the gas end cap (Fig. 14a) indicates the true precharge pressure.**
- **In applications where an accumulator is coupled to a gas bottle: A Hall Effect proximity sensor can be installed in the accumulator gas end cap (Fig. 14b) to detect when the piston comes within .050 inch of the cap. This system would provide a warning when precharge pressure has dropped and remedial action should be taken.**

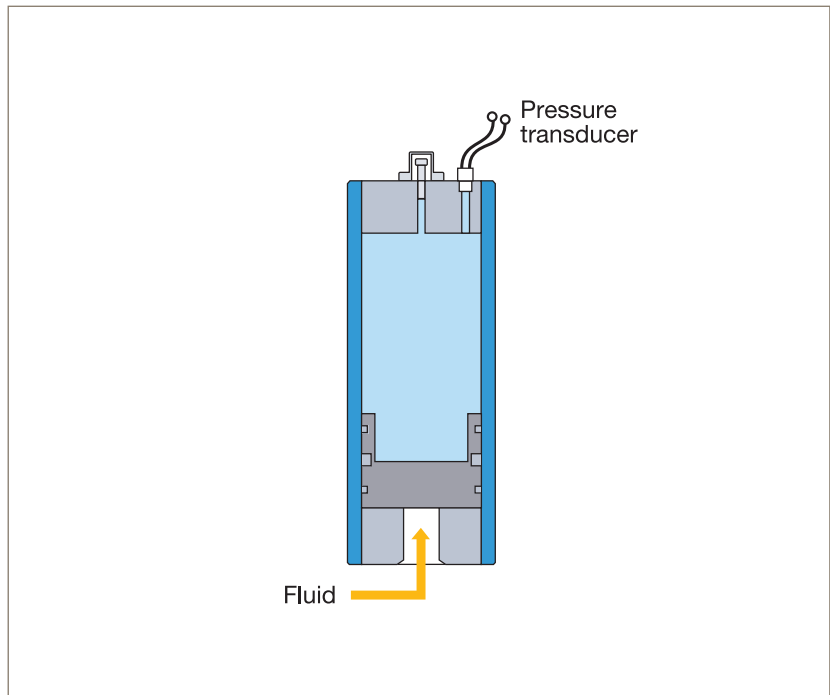

Fig. 14a Pressure transducer measures actual precharge pressure of shut down system

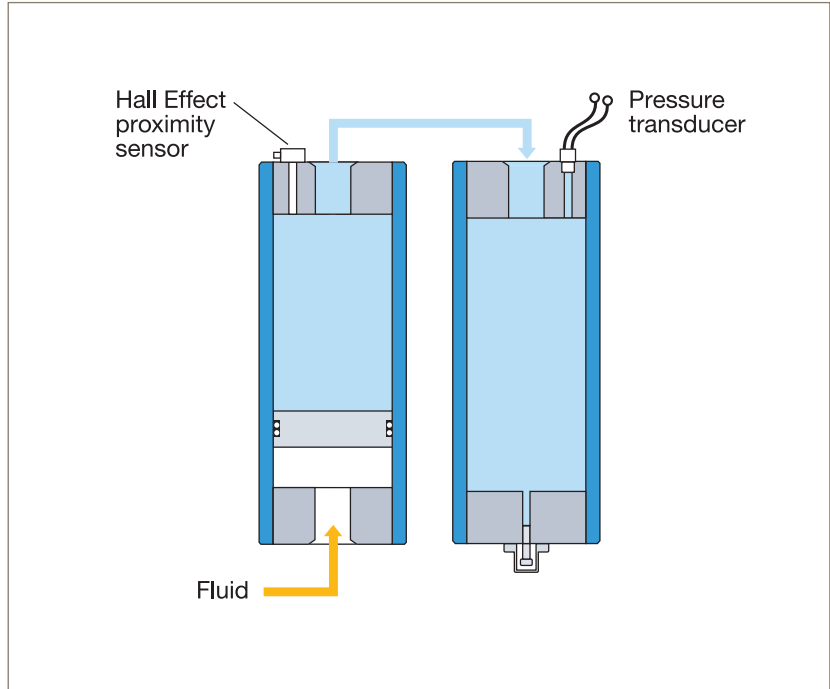

Fig. 14b Hall Effect sensor registers proximity of piston to end cap

- In applications where it is desirable to know when the piston is approaching the gas cap of the accumulator or to detect a low precharge, as the rod is detected by the reed or proximity switch, the switch could be set up to send out a warning signal (Fig. 14c).

When used with a pressure switch, it could detect a low precharge.

In some instances two reed or proximity switches could be installed on the housing. In such a case it may be required that the first switch is always made, assuring us that the precharge is not too high, if the second switch is made, it would report that the precharge is too low.

The position of the piston can be detected by a fraction of an inch to several inches before it reaches the end cap.

- When it is required to know the exact location of the piston inside the accumulator, use a linear displacement transducer (LDT) (Fig. 14d). Positions as well as velocity can be determined by the use of this unit. An LDT works by sending a signal down the probe. This signal is then reflected by a magnet attached to a rod and piston assembly. The LDT records the amount of time between sending and receiving the reflected signal and then calculates the position of the piston. Multiple signals will allow the unit to calculate velocity. Using this unit will allow the user to know the exact volume of fluid in the accumulator as well as the flow rate of the fluid.

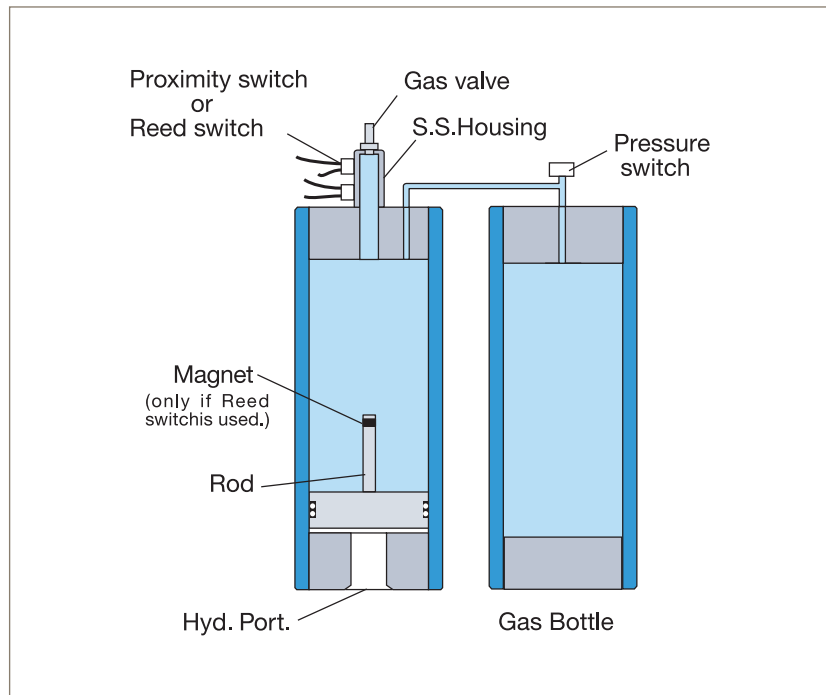

Fig. 14 c Proximity switches can sense the position of an approaching piston

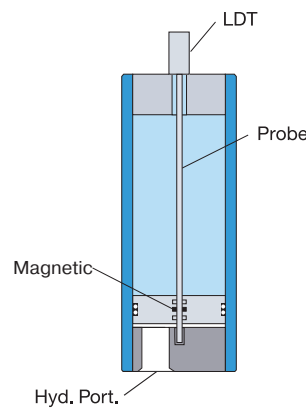

Fig. 14d Linear Displacement Transducers (LDT) can accurately detect both piston location and velocity

Failure Prevention

Accumulator failure is generally defined as inability to accept and exhaust a specified amount of fluid when operating over a specific system pressure range. Failure often results from an unwanted loss or gain of precharge pressure.

Correct precharge pressure is the most important factor in prolonging accumulator life. If maintenance of precharge pressure and relief valve settings is neglected, or if system pressures are adjusted without making corresponding adjustments to precharge pressures, shortened service life will result.

Bladder accumulators

Bladder/Diaphragm accumulator failure occurs instantaneously from bladder/diaphragm rupture (**Fig. 15**). Rupture cannot be predicted because the intact bladder or diaphragm is essentially impervious to gas or fluid seepage; no measurable gas or fluid leakage through the bladder or diaphragm precedes failure.

Piston accumulators

Piston accumulator failure generally occurs in one of the following gradual modes.

Fluid leaks to the gas side

This failure, sometimes called dynamic transfer, normally takes place during rapid cycling operations after considerable time in service. The worn piston seal carries a small amount of fluid into the gas side with each stroke.

As the gas side slowly fills with fluid, precharge pressure rises and the accumulator stores and exhausts decreasing amounts of fluid. The accumulator will totally fail when precharge pressure equals maximum hydraulic system pressure. At that point, the accumulator will accept or deliver any fluid. Because the rise

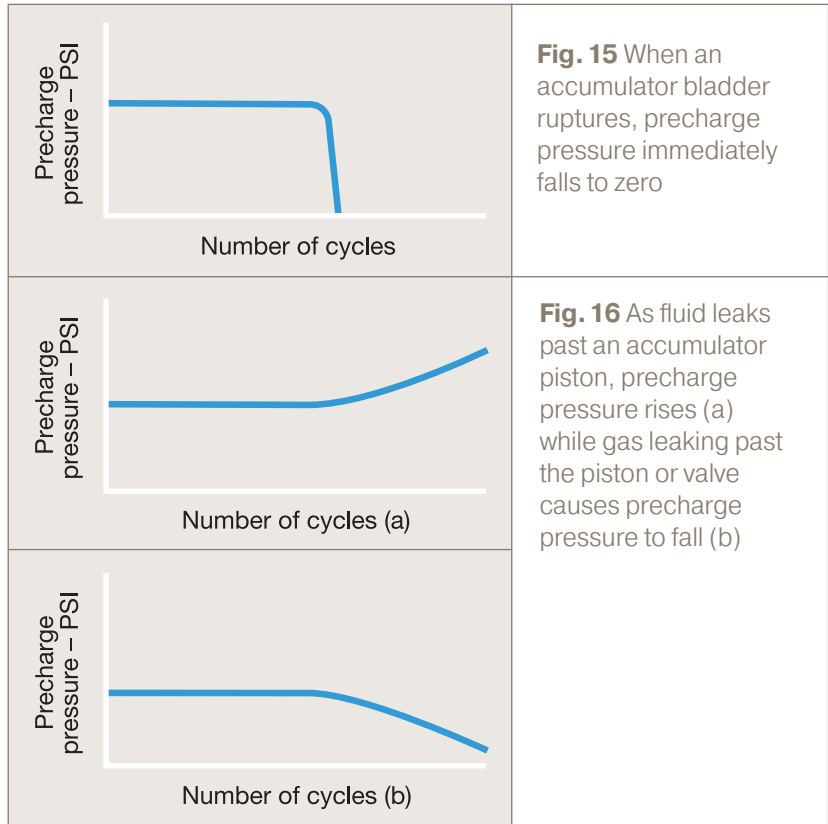

in precharge pressure can be measured (**Fig. 16a**), failure can be predicted and repairs effected before total failure occurs.

Gas leakage

Precharge may be lost as gas slowly bypasses damaged piston seals. Seal deterioration occurs from excessively long service, from fluid contamination, or from a combination of the two. Gas can also vent directly through a defective gas core or end cap O-ring. The reducing precharge pressure then forces progressively less fluid into the system. Because this gradual decrease in precharge pressure can be measured (**Fig. 16b**), repairs can again be effected before total failure occurs.

A correctly specified Parker accumulator, installed and maintained in accordance with the guidelines contained in this section, will give many years of trouble-free use. The combination of clean system fluid and accurate precharging will prevent most of the common fault conditions described here, and will contribute to the long life and high operating efficiency of the entire hydraulic system. It is recommended to use Parker filters to keep contaminants out of your system.

Solutions for Oil & Gas and Power Generation

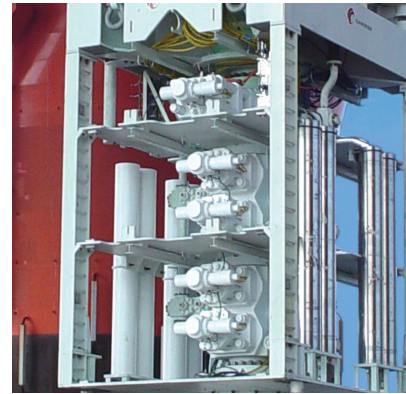

For today's power generation accumulator needs in oil and gas production, wind power, wave power, nuclear, hydro-electric, turbine and valve actuator applications, Parker has the most complete selection of solutions.

In fact, our unrivaled strengths can significantly help improve your operations' efficiency, productivity, safety and profitability. With more than 50 years of experience, unsurpassed application and engineering expertise, industry-leading production capabilities and 24/7 global accessibility, Parker's

Global Accumulator Division is your total advantage. See for yourself why we're the trusted supplier to a major share of today's worldwide market.

The vast product range you expect

At Parker, we engineer and manufacture a complete line of hydraulic accumulators and accessories. Our piston product line is the industry's largest. And the respected heritage of Greer is integrated in today's Parker bladder accumulator technology and capabilities. Combined, these strengths bring you one uniquely powerful advantage.

Parker custom-engineers up to 600-gallon capacity piston accumulators, including these 80-gallon special-grade stainless steel designs for 10,000 to 12,000-ft. subsea depths.

In addition, we are a leader in meeting special piston accumulator requirements, supplying bladder accumulators to the oil and gas industry, multiple certifications and meeting the dynamic requirements of global certifications.

Engineered custom-design solutions

When you need a custom accumulator solution, whether it's to solve a problem or optimize an opportunity, you need rapid-response expertise. Parker quickly sets your ideal solutions in motion with unmatched experience and capabilities.

Our custom advantages include:

- **modifying standard designs to your specifications**
- **bladder injection molding and rubber compound capabilities**
- **all grades of steel, stainless, exotics – plus new weight-saving composite designs**
- **sensors technology**
- **pulsation and shock dampening**

In addition, we possess leading expertise in special mounting, rack configurations and complete systems including manifolds and frames.

The world-class support you deserve when your operations go to emergency power, will the accumulators work the first time, every time? For the most critical scenario as well as utmost reliable day-to-day performance, every Parker accumulator that goes to work in a BOP control unit, tensioner system or compensator first meets or exceeds the highest standards in design and stringent testing.

Our quality system has been audited by such industry experts as ABS, DNV, ASME, PED, plus governmental and aerospace agencies. And as you'd expect, we are ISO 9001 certified. Your bottom line also benefits from



our lean processes and state-of-the-art systems that ensure the highest quality – with the industry's shortest lead times. And we deliver our product when you need it. Our proven delivery performance is rooted in tradition and team-driven each day at Parker.

We continually consider your big picture, as well. Beyond drilling and development, you can also turn to our broad accumulator expertise to pursue improvements in the facets of exploration, storage, transport and refining.

Global presence, immediate accessibility Above all, whenever and wherever in the world you need us, Parker is there with the assistance and information you need.

For custom-design initiatives and solutions, customers worldwide look to Parker's superior engineering capabilities and technology first.

Parker accumulator customers have the leading advantage of our:

- **sales and service offices located globally**
- **worldwide distribution network**
- **manufacturing facilities on five continents**
- **emergency delivery with a toll-free call**
- **inPHorm™ sizing and selection software**
- **instant information at www.parker.com/accumulator**
- **the industry's most complete print materials**

By far, your greatest value-added advantage in accumulators is Parker's Global Accumulator Division. For the details and assistance you need to put our strengths to work for your operations, contact us.

Solutions for Mobile Applications

From construction sites to farmlands, forests and more, the challenges for mobile hydraulics are wide-ranging and varied. Yet the foremost demands are the same: Total reliability whatever the conditions and optimum performance from start up to shut down.

For peak performance and efficiency in mobile equipment, Parker's Global Accumulator Division has the most complete selection of solutions. We bring you the most experience in the industry, unsurpassed application and engineering expertise, industry-leading production capabilities and 24/7 global accessibility.

Accumulator advantages

Reduced shock loads, lower noise levels and reduced energy consumption are among the primary benefits of specifying an accumulator in a hydraulic system. Smaller pumps, motors and reservoirs save installation space and cost, while the inherent fail-safe performance of a piston accumulator provides safe operating margins for braking and steering systems.

Accumulators also can benefit hydraulic systems by providing:

- **an auxiliary power source for use during peak periods**
- **protection from damage due to thermal expansion and contraction in a closed system**
- **compensation for changes in fluid value to assure a positive pressure**
- **emergency fail-safe power**
- **maintained necessary pressure for long periods of time**
- **fluid dispensing at a slow, constant rate to critical equipment wear areas**



In the longer term, reduced operator fatigue and extended maintenance intervals also help to reduce ownership costs and boost operational productivity.

Look to the global leader

Parker supplies the industry's broadest hydro-pneumatic accumulator product line, including pistons, bladders and diaphragms. In fact, the well-known Greer bladder accumulator line is part of today's Parker advantage. As a result, without limitations or bias, we recommend and supply the best-engineered solution based on your application.

You can depend on Parker's unmatched strengths in:

- **state-of-the-art technology**
- **lean processes resulting in the industry's shortest lead times**

- **the industry's top technicians and professionals**
- **leadership in engineered custom-design work**
- **certification capabilities for today's global demands**

Parker technology and lean manufacturing

Years of lean manufacturing principles allow us to turn your order around quickly and efficiently. We use highly flexible automation, high-precision injection molding machines and robotic machining cells to produce the highest-quality bladder and piston accumulators. Every accumulator is pressure tested to excellent quality standards before it ships to the customer. And as you'd expect, we are ISO 9001 certified.

The right solution for your application

As a major industry supplier of all three types of accumulators, we first evaluate your needs and opportunities to increase the performance, efficiency and value of your product. We recommend the ideal solution based on your specific situation and criteria. We then ensure that your accumulators are manufactured with the best-grade materials to the highest industry standards. And we provide the required labeling, specially designed packaging and shipping containers to meet today’s critical safety and environmental regulations.

Leading engineered custom design

Due to our strong engineering capabilities, you can also look to Parker first for custom-design initiatives and solutions, including:

- **efficient modification of standard designs to your specifications**
- **custom rubber compression molding capabilities**
- **all grades of steel, stainless and exotics, as well as advanced performance materials**
- **temperature pressure and positioning sensors technology**
- **special mounting, including bank (rack) configurations of multiple accumulators**

Unsurpassed reliability and responsiveness

Parker accumulators are at work in mobile and industrial equipment worldwide – including some of the harshest environments on earth. For our superior capabilities, experience and service, major OEMs have made us their supplier of choice. In fact, we are the trusted supplier to a major share of today’s accumulator market.

Equally important, our worldwide service, distribution and sales network keeps us responsive and accessible to you anywhere, anytime.

Parker accumulator customers have the advantages of our:

- **sales and service offices located globally**
- **worldwide distribution network**
- **manufacturing facilities on five continents**
- **emergency delivery with a toll-free call**
- **inPHorm™ sizing and selection software**
- **instant information at www.parker.com/accumulator**
- **the industry’s most complete print materials**

For the details and assistance you need to put our strengths to work in your mobile applications, contact Parker’s Global Accumulator Division.

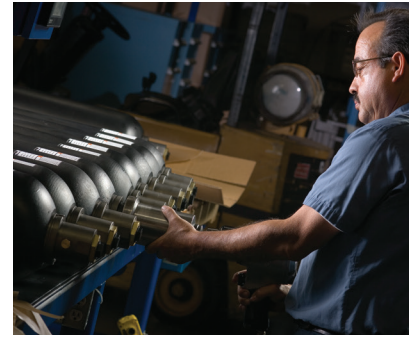

Every accumulator is pressure tested before it ships to the customer.

Typical Mobile/Industrial Applications and Advantages Include:

- **emergency backup for steering, brake and pilot circuits**
- **shock absorption in hydrostatic drives**
- **pressure spike dampening in fork lifts/cherry pickers**
- **optimized suspension and braking systems performance**
- **reduced pulsations in plunger and diaphragm pumps**
- **injection molding and die cast equipment (high pressure and flows in short time period)**
- **maintained pressure and reduced pump size in machine tools**
- **oil supply for turbine engine lubrication**
- **winches (maintaining line tension)**
- **auxiliary/emergency power**

Installing an accumulator can save you time and money



Applications

The Parker ACDE gas loaded accumulator is an essential component for the optimum operation of a hydraulic circuit. In hydraulic circuits, the accumulator enables:

Energy Storage: saves energy without loss and redistributes when required therefore reducing installed power.

Pressure compensation: absorbs pressure spikes from pumps or other components to control pressure and flow-rates in a hydraulic circuit.

Volume Control: absorbs fluid volume variations induced by temperature changes in a closed hydraulic circuit and maintains a rated pressure.

Maintains Fluid Flow Rate: an accumulator can maintain the fluid flow rate in case of pump failure and can also be used as a mobile fluid reserve under pressure.

Emergency Energy Storage: in case of failure of the main energy source, an accumulator can provide sufficient energy to complete an operation or to realize a full hydraulic cycle.

Prevents mixing of fluids: Transfer of energy from a fluid to another fluid without any risk of mixing

Shock absorber: suppresses shocks and vibrations in hydraulic systems of lifting vehicles (e.g. Forklift trucks) and maintains real suspension of the load on a gas spring.

Accumulators - Advantages / Your benefits

- **Reduction in working costs**
 - Energy reserve
 - Reduces installed electrical power
- **Increases lifetime of equipment**
 - Reduces pulsations
 - Protects against pressure peaks
- **Reduction in maintenance costs**
 - Reduces wear of hydraulic components
 - Requires minimum maintenance
- **Emergency Energy Back-up**
 - Energy reserve

Accumulator operating principle

Operation of the gas loaded bladder accumulator is based on the considerable difference in compressibility between a gas and a liquid, enabling a large quantity of energy to be stored in an extremely compact form. This enables a liquid under pressure to be accumulated, stored and recovered at any time.

Piston Accumulators

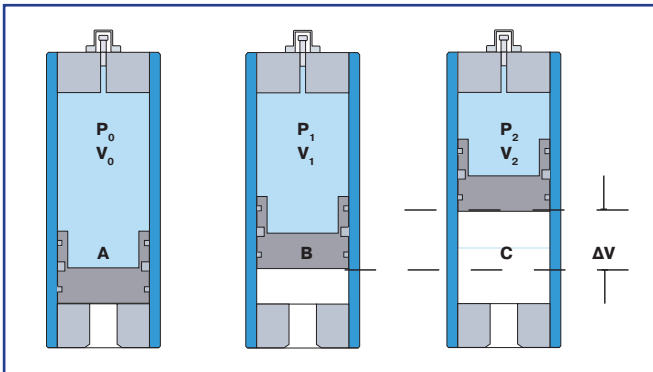

When fluid under pressure enters the fluid side of the accumulator, the piston is pushed towards the gas side and the Nitrogen gas is compressed.

Bladder Accumulators

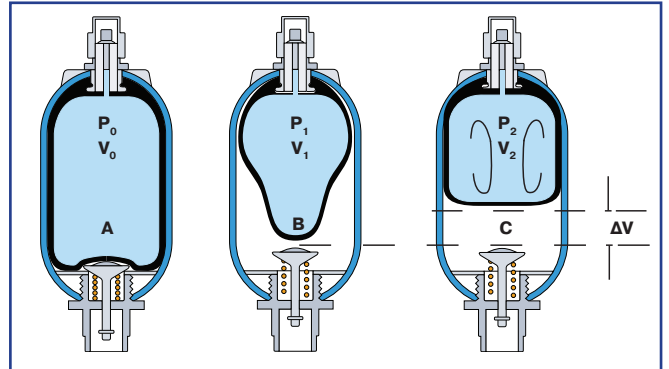

A - Bladder in the Pre-charge position, which means that the accumulator only contains nitrogen. The anti-extrusion system closes the hydraulic orifice which prevents the destruction of the bladder. In low pressure accumulators the bladder rests against the grid. Maximum pressure differential (P_2/P_0): 4:1

B - Position at the minimum operating pressure. There must be a certain amount of fluid between the bladder and the hydraulic orifice, such that the anti-extrusion system does not close the hydraulic orifice.

C - Position at the maximum operating pressure. The volume difference between the minimum and maximum positions of the operating pressures represents the working fluid quantity.

Diaphragm Accumulators

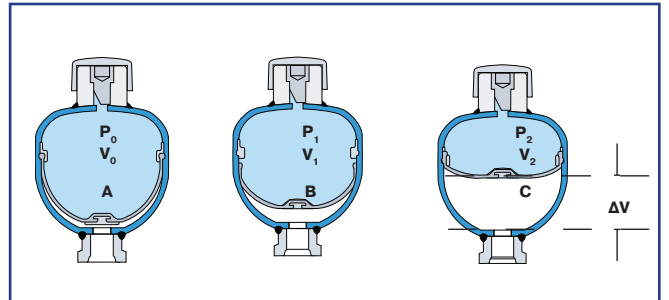

A - The diaphragm is in the Pre-charge position, which means that it is only filled with nitrogen. The knob closes the hydraulic orifice and prevents the destruction of the diaphragm.

B - Position at the minimum operating pressure : there must be a certain amount of fluid between the diaphragm and the hydraulic orifice, such that the knob does not close the hydraulic orifice. Thus, P_0 must always be $< P_1$.

C - Position at the maximum operating pressure: the volume change ΔV between the minimum and maximum positions of the operating pressures represents the fluid quantity stored.

KEY

V0 = Capacity in nitrogen of the accumulator

V1 = Gas volume at the minimum hydraulic pressure

V2 = Gas volume at the maximum hydraulic pressure

ΔV = Returned and/or stored volume of working fluid between P_1 and P_2

P0 = Initial preload of the accumulator

P1 = Gas pressure at the minimum hydraulic pressure

P2 = Gas pressure at the maximum hydraulic pressure

Regulations & Approvals

Parker designs and manufactures gas loaded accumulators for use in all countries, as well as other industry specific approvals including Oil & Gas, Naval and Nuclear. The main regulations in force are PED for European market, ASME for US market and SELO for Chinese market.

As a service, Parker Olaer can recommend the appropriate regulations applicable if customers know the country where the accumulator will be installed. When operating in dangerous and explosive

environments, Parker has developed high-tech solutions. Some of these regulations call for the use of safety devices to protect the accumulator against over pressure. Solutions may include hydraulic safety blocks, relief valves or gas side safety devices such as burst discs and fuse plugs. Parker has designed and proposed a complete range of safety devices suitable for the applicable regulations.

To meet the needs of our customers, Parker can supply accumulators with multiple approvals. With regard to environmental concerns Parker's product range complies with REACH regulations. Each accumulator is delivered with the certificate of conformity. Documents can be accessed at any time and from any location.

<https://divapps.parker.com/divapps/CADE/DMS/>

Do you need multi-international certification?



The Global Bladder Accumulator Series

Multi-international certification

In April 2017 Parker launched the first global accumulator offering multi-international certification (SELO, ASME & CE) as well as improved technology and design.

Only 11 countries in the world are not covered by this multi-international certification. All regulations have been combined which has significantly reduced the amount of part numbers and complexity of documentation therefore providing a significant reduction of cost and resources for your design and logistic departments.

All of the global accumulators will have a unique code so that you can benefit from the Parker Tracking System (PTS).

CADE Accumulator Range on parker.com

View Cylinder and Accumulator Division Europe's vast range of membrane, bladder and piston accessories, as well as all needed accessories online on parker.com
For more information about our products, please consult your local Parker representative.





RCC-M







Regulations and Protections
EBV and EHV series



ENGINEERING YOUR SUCCESS.

Regulations & Approvals for EBV & EHV Bladder Accumulators

Due to our vast experience in demanding markets such as aerospace, military, nuclear, renewable energies and formula one racing, we are offering an unmatched range of rubber compounds to meet the most difficult applications.

Parker Olaer products are supported all over the globe, and we will meet customer requirements wherever needed. We therefore offer the complete range of approvals, such as all key Marine approvals (BV, DNV, ABS, LR, ...), over and above all country specific approvals (PED, AS 1210, ASME, SELO, CRN, ARH, CUTR, ...)

please refer to this document for further information

MSG01-6975



European Headquarters
La Tuilière 6, 1163 Etoy,
Switzerland
Tel: +41 21 821 85 00